

Rittal – The System.

Faster – better – worldwide.

Innovations 2010



All supplements to Catalogue 32

FRIEDHELM LOH GROUP



Rittal – The System.

Faster – better – worldwide.





Our strategy centres around comprehensive system solutions and understanding our customers' needs. This is translated into an individual system that is sure to impress, due to its logical structure, flexible functions, maximum modularity, simple mechanical engineering, direct availability and global presence. Quite simply, Rittal offers all this with a single system.

We guarantee comprehensive planning, engineering and a range of complimentary services, all in keeping with our basic principle:

Rittal – The System.
Faster – better – worldwide.

- **Service and support**
- **Software and planning**
- **Products**

Contents:

Industrial enclosures	4
Power distribution	12
System climate control	20
IT systems	34
System accessories	42
List of model numbers	43
Index	43

Powerful design. Flexible applications.



Support arm system CP-C component overview

- 1 Support section CP-C, closed (CP 6074.000, .100, .300, .500)
- 2 Support section CP-C, open (CP 6075.100, .300, .500)
- 3 Enclosure attachment CP-C (CP 6070.200)
- 4 Housing coupling CP-C (CP 6070.000)
- 5 Angle coupling 90° CP-C (CP 6071.200)
- 6 Angle piece 90° CP-C (CP 6071.400)
- 7 Intermediate hinge CP-C (CP 6071.800)
- 8 Top-mounted joint CP-C, vertical outlet (CP 6072.800)
- 9 Wall-mounted joint CP-C, vertical outlet (CP 6072.400)
- 10 Top-mounted joint CP-C, horizontal outlet (CP 6072.600)
- 11 Wall-mounted joint CP-C, horizontal outlet (CP 6072.500)
- 12 Wall/base mounting bracket, small CP-C (CP 6072.200)
- 13 Wall/base mounting bracket, large CP-C (CP 6072.000)
- 14 Mounting component (CP 6073.000)

Support arm configurator

The configurator determines the correct support arm system according to user-specific parameters.

**Further information
is available at:
www.rittal.com/configurators**



System-compatible



Matching operating housings for support arm systems include for example:
Comfort Panel, Cat. 32, page 192
Optipanel, Cat. 32, page 204
System overview Cat. 32, page 190 – 191

**Further information
is available at:
www.rittal.com/configurators**

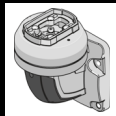
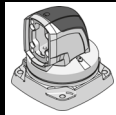
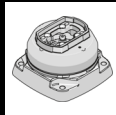
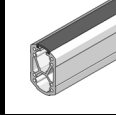
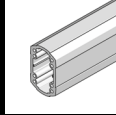
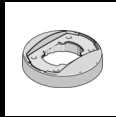

Support arm system CP-C

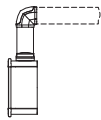

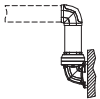
	swivel	rigid	Length mm	Weight kg	Enclosure section	Desk section	Wall section
							
Model No. CP							
Enclosure attachment CP-C	-	■	-	0.7	6070.200	-	-
Housing coupling CP-C	■	-	-	2.0	6070.000	-	-
Angle coupling 90° CP-C	■	-	-	2.1	6071.200	-	-
Support section CP-C	-	-	250 500 1000 2000	2.0 3.9 7.8 15.6	6074.000 6074.100 6074.300 6074.500		
Support section CP-C, open	-	-	500 1000 2000	4.6 9.2 18.4	6075.100 6075.300 6075.500		
Angle piece 90° CP-C	-	■	-	1.1	6071.400	-	6071.400
Intermediate hinge CP-C	■	-	-	4.4	-	6071.800	-
Top-mounted joint CP-C (vertical outlet)	■	-	-	3.8	-	-	6072.800
Top-mounted joint CP-C (horizontal outlet)	■	-	-	4.3	-	-	6072.600
Wall-mounted hinge CP-C (vertical outlet)	■	-	-	5.5	-	-	6072.400
Wall-mounted hinge CP-C (horizontal outlet)	■	-	-	6.1	-	-	6072.500
Wall/base mounting bracket, small, CP-C	-	■	-	0.5	-	-	6072.200
Wall/base mounting bracket, large, CP-C	-	■	-	2.5	-	-	6072.000

Support arm system CP-C

Load capacity

Permissible load depending on system configuration

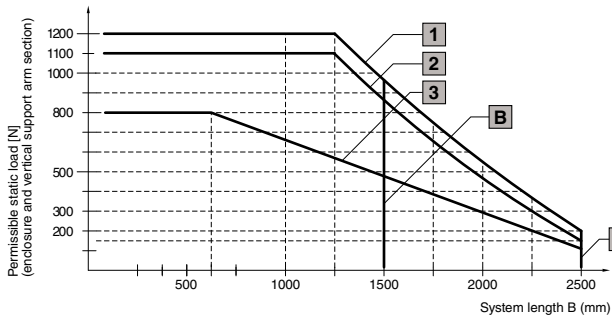

1 Without intermediate hinge

2 With intermediate hinge CP 6071.800 and closed support section

3 With intermediate hinge CP 6071.800 and open support section

Wall/base mounting bracket, small CP 6072.200 must not be used in conjunction with intermediate hinge CP 6071.800!

A Maximum system length 2500 mm for systems with horizontal outlet at the system start.

B Maximum system length 1500 mm for systems with vertical outlet at the system start.

1 System configuration without intermediate hinge, CP 6071.800

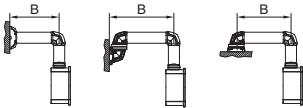

1 System configuration without intermediate hinge, CP 6071.800

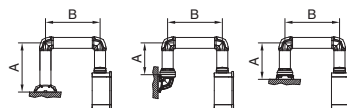

2 3 System configuration with intermediate hinge, CP 6071.800¹⁾

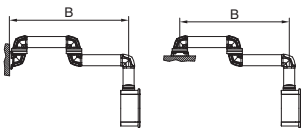

2 3 System configuration with intermediate hinge, CP 6071.800¹⁾

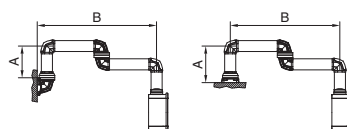

B max. = 2500 mm

A max. = 500 mm B max. = 1500 mm

¹⁾ Intermediate hinge CP 6071.800 should only be used once per system!

Support section CP-C, open

Attachment to the connection components with 4 self-tapping screws in the screw channel, may be cut to any required length, no thread-tapping required. With open cable duct, for easy servicing access and for pre-assembled cables with connectors; easily locked via cover section. X-shaped profiling for greater load capacity with large cable routing channels. Upper channel adequate for cables with large connectors (e.g. DVI or VGA) and available/usable throughout the entire system.

Dimensions:

75 x 120 mm

Material:

Support section: Extruded aluminium section
Cover: Plastic

Colour:

Support section: RAL 7035
Cover: RAL 7024

Length mm	Weight kg	Model No. CP
500	4.6	6075.100
1000	9.2	6075.300
2000	18.4	6075.500



Rittal service:

Individual lengths available on request.

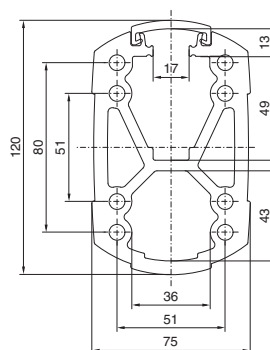

Support arm system CP-C



Wall/base mounting bracket, large, CP-C

For rigid attachment of the support arm system to vertical or horizontal surfaces.

Benefits:

- Prepared for flexible cable entry and routing from all sides.
- Integral one-man assembly via machined keyholes
- Optional anti-twist attachment onto the mounting surface by pinning
- Integral adjustment facility

Material:

Wall/base mounting bracket, large:
Cast aluminium
Cover: Plastic

Colour:

Wall/base mounting bracket, large: RAL 7035
Cover: RAL 7024

Supply includes:

Seals, self-tapping screws and grub screws for CP-C support section attachment and for adjustment.

Weight kg	Model No. CP
2.5	6072.000

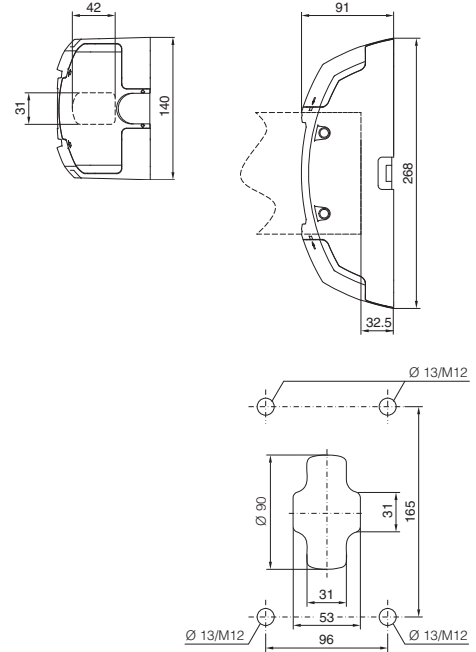

Connection adaptor CP-C to CP-L

Applications:

- For integration of the support arm, height-adjustable CP-L (Innovations 2009, page 27) to the CP-C support arm system
- For mounting small, flat operating housings if the load capacity of the support arm system CP-C is needed for long jib lengths

Benefits:

- Integral adjustment facility

Material:

Cast aluminium

Supply includes:

Seals and self-tapping screws for CP-L support section attachment.

Weight kg	Model No. CP
0.6	6071.600

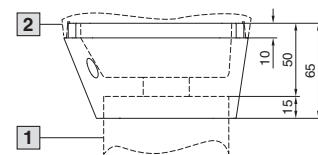

- 1 Support section CP-L
Support arm, height adjustable CP-L
- 2 Connection of the CP-C system components
CP 6071.400, CP 6071.800



The Rittal connector gland proves that sometimes “less is more”: significantly faster installation, a flexible sealing system for different cable diameters and simple cable entry with pre-assembled cables. Low installation costs, a high degree of protection and flexible cable management – added value guaranteed with the latest generation of cable entry solutions from Rittal.

Benefits:

- Cable diameters 4 – 16 mm
- Simple cable entry for pre-assembled cables
- Individual cables can be added or replaced without dismantling the sealing frame
- Sealing modules remain safely attached to their cables

Photo shows a configuration example with equipment not included in the scope of supply.

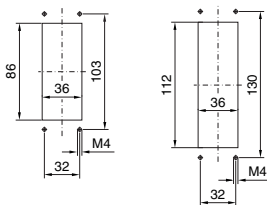

16-pole

24-pole

Sealing frame

For pre-assembled cables with connectors.

Mounting over 24-pole or 16-pole connector cut-outs in:

- Module plates for TS divider panels
- Metal gland plates

Material:

Frame: Polyamide
Flat seal: CR

Protection category:

IP 64 to EN 60 529, complies with NEMA 12.

Supply includes:

Assembly parts.

For modules 20 x 20 mm	For cut-out	Packs of	Model No. SZ
10 modules	24-pole	1	2400.900
8 modules	16-pole	1	2400.910



Accessories:

Module plates for TS divider panels, see Catalogue 32, page 923.



Sealing modules

To seal cables in conjunction with a sealing frame. It is possible to combine 20 x 20 mm and 40 x 40 mm sealing modules.

Material:

Hard shell: Polyamide
Seal: LSE 2

Protection category:

IP 64 to EN 60 529, complies with NEMA 12.

Sealing modules 20 x 20 mm		
Diameter range	Packs of	Model No. SZ
4 – 6 mm	10	2400.920
6 – 9 mm	10	2400.930
solid	10	2400.970

Sealing modules 40 x 40 mm		
Diameter range	Packs of	Model No. SZ
9 – 12 mm	10	2400.940
12 – 16 mm	10	2400.950
solid	10	2400.960

Hygienic Design



Simple cleaning

- Inclined surfaces: 3° on all sides, 10° on the cover
- All-round gap-free silicone seal between enclosure and cover
- Hygiene-compliant hexagon locks

Easy assembly

- Quick-release cover locks
- Simple replacement of the silicone seal

Component installation

- Hole pitch of 6.25 mm for greater flexibility
- KL support rails and mounting plates can be fitted directly



Hygienic Design

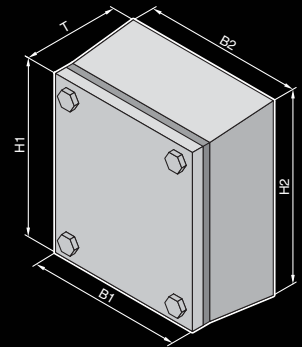

Material:

Enclosure and cover: Stainless steel 1.4301 (AISI 304), 1.5 mm
 Mounting bracket: Sheet steel, zinc-plated, 2.0 mm
 Quick-release locks: Stainless steel 1.4301 (AISI 304)
 Seal: Silicone, compliant with FDA 21 CFR 177.2600

Surface finish:

Enclosure and cover: Brushed, grain 400, $R_A < 0.8 \mu\text{m}$
 Seal: Blue, dyed (RAL 5010)

Protection category:

IP 66 to EN 60 529

Supply includes:

Enclosure with unbroken surface, cover, mounting bracket (pre-assembled), seal and quick-release locks (enclosed).



Accessories:

Cable glands HD, see Cat. 32, page 1056.

Detailed drawing, available on the Internet.

Photo shows a configuration example with equipment not included in the scope of supply.

Terminal boxes HD

Width	front (B1) mm	Packs of	150	150	200	300	400	Cat. 32, page
	rear (B2) mm		172	177	227	327	427	
Height	front (H1) mm		150	150	200	200	200	
	rear (H2) mm		172	177	227	227	227	
Depth	(T) mm		80	120	120	120	120	
Model No. HD		1	1670.600	1671.600	1672.600	1674.600	1675.600	
Accessories								
Wall spacer 50 mm		1	4000.100	4000.100	4000.100	4000.100	4000.100	301
Mounting plate		1	1560.700	1560.700	1562.700	1563.700	1564.700	978
Support rail TS 35/7.5		10	2314.000	2314.000	2315.000	2316.000	2317.000	1002

Power Engineering 5.0

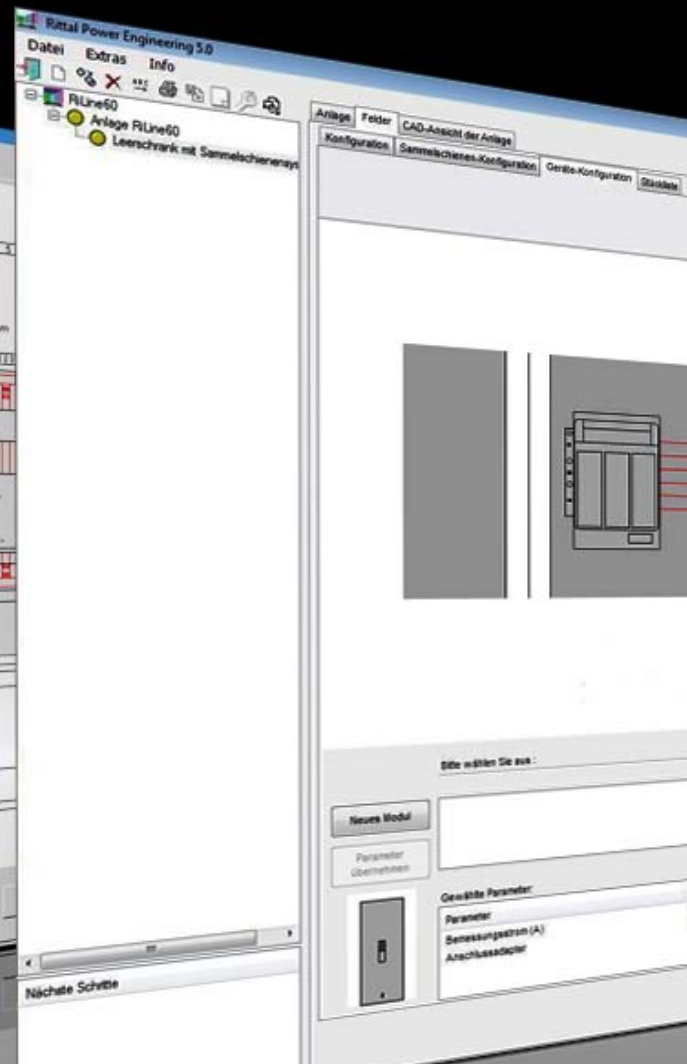
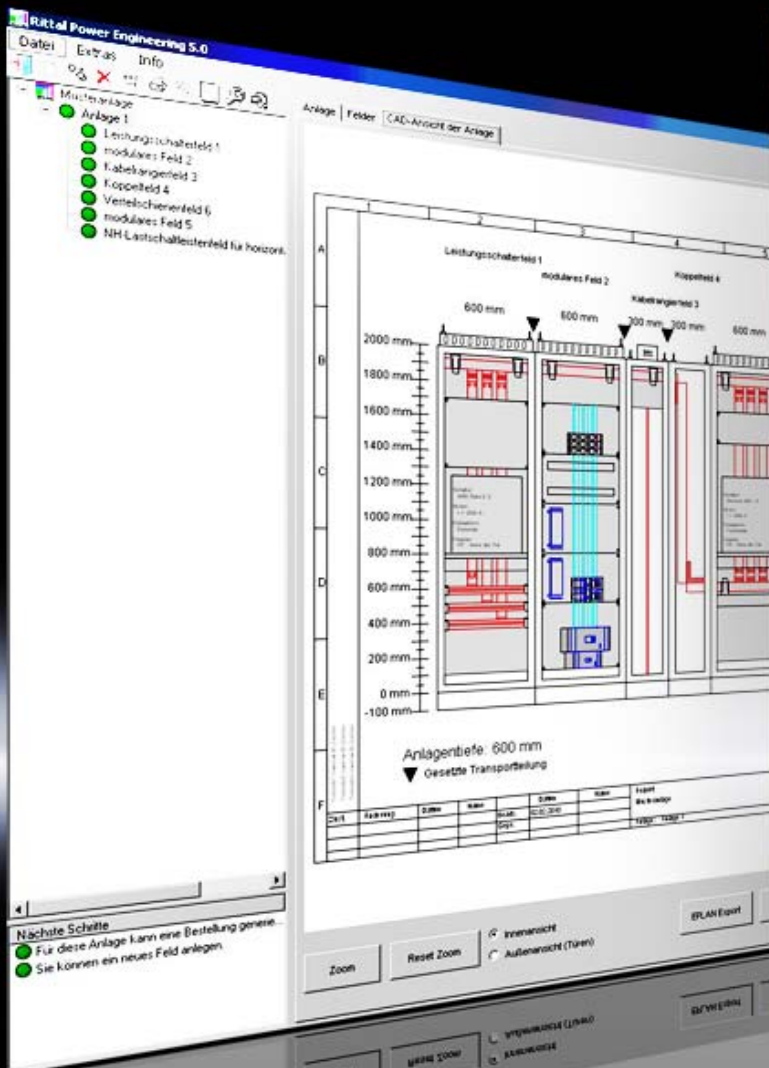

Quick and easy switchgear planning

- For Ri4Power low-voltage switchgear and RiLine60 busbar systems
- Simple selection and graphic positioning of assemblies
- Automatic generation of component parts lists
- Access to the entire range of Rittal products
- Multi-lingual program guidance

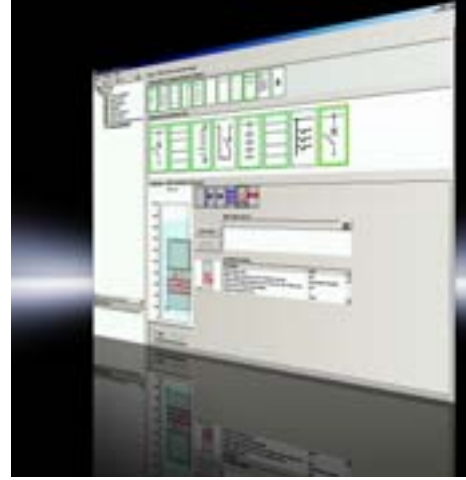

Configuration of RiLine60

- Configuration of RiLine60 busbar systems in the Top enclosure system TS 8
- Easy selection of units and adaptors
- Integral database of switchgear from well-known manufacturers
- Automatic calculation of rated currents and heat losses



Assembly diagram – Assembly made easy

- Automatic generation of panel-specific assembly diagrams
- Support with pre-production and assembly
- Direct allocation of components to the installation location
- Efficient, systematic assembly

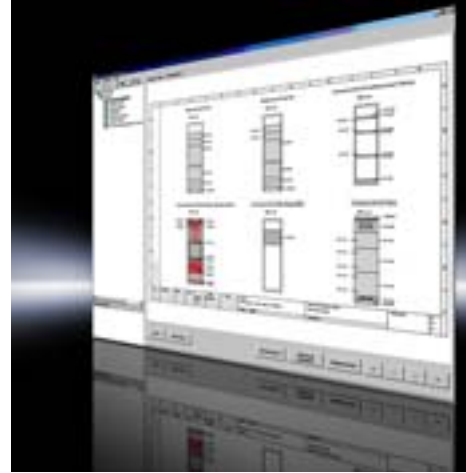

Program interfaces

- Export interface Eplan Electric P8
- Export of parts lists in MS Excel format
- CAD export in DWG or DXF format
- Tender specification texts in MS Word format
- Import/export interfaces for data updates



RiLine60 Plus



Fast assembly

Busbar supports

SV 9340.000, .010, .050, .004

- Steps for adapting to the flat bar cross-section may be locked using a pin
- Bars may be inserted from the front, or slide in from the side.



Busbar connection adaptor

SV 9342.220 – .324

- Cable entries: Perforation facilitates toolless machining by simply knocking out
- Prepared for round conductors and laminated copper bars.



OM adaptor and OM support

SV 9340.260 – .930

- Side anti-slip guard ensures a secure grip on the busbar
- Suitable for use on 4-pole busbar system with and without base tray
- Support rails: Now only one design for adaptor section and support frame



Simple planning

Power Engineering 5.0

SV 3020.500

- Configure RiLine60 busbar systems and components in the Rittal TS 8 Top enclosure system
- Generation of parts lists with graphical output
- Calculation of rated current and heat loss

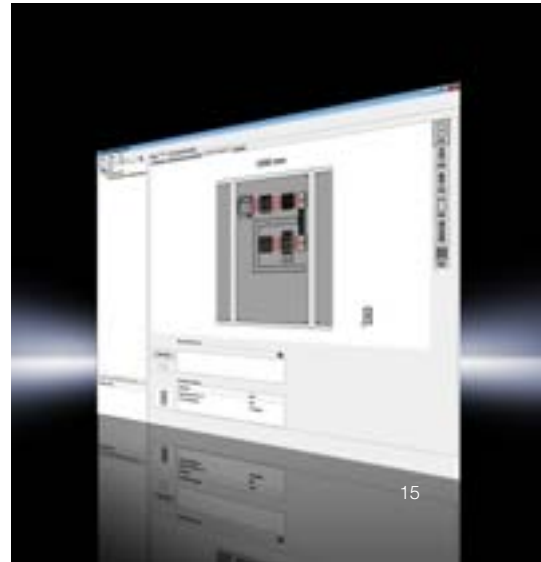

Ri4Power Form 1-4



Yet more options

- Identical system structures for all Forms from 1 to 4b
- Simplified, cost-saving assembly operations
- Even more solutions for low-voltage switchgear, thanks to an extended range of combinations

3 busbar systems up to 5500 A

- RiLine60 – Versatile thanks to sophisticated adaptor technology
- Maxi-PLS – The assembly-friendly modular system
- Flat-PLS – The flat bar system for discerning requirements
- Optimum dimensioning of the rated current
- High levels of short-circuit resistance up to 100 kA for 1 sec./220 kA

System accessories

- Versatile applications thanks to TS 8 system technology
- Simple assembly
- Suitable for individual applications
- Increased contact hazard protection thanks to Form 4b terminal compartment cover



Ri4Power



Busbar support

Busbar support, suitable for top mounting

For the assembly of Maxi-PLS busbar systems
3/4-pole

Material:
PA 6

Supply includes:
Assembly parts.

For Maxi-PLS	Packs of	Model No. SV
1600/2000	1	9649.160
3200	1	9659.160



Isolator chassis

for Maxi-PLS

For isolated routing of the connection brackets.

Material:
PA 6.6

Supply includes:
Assembly parts.

For Maxi-PLS	Bar centre distance mm	For connection bracket width mm	Packs of	Model No. SV
1600/2000	100	60	1	9640.021
3200	150	60	1	9650.021
3200	150	100	1	9650.031



Contact piece

for Maxi-PLS

For contacting the connection brackets to the
Maxi-PLS busbars.

Material:
E-Cu

Supply includes:
Sliding block, assembly screw.

For Maxi-PLS	For connection bracket width mm	Packs of	Model No. SV
1600/2000	60	1	9640.171
1600/2000	100	1	9640.181
3200	60	1	9650.171
3200	100	1	9650.181



Also required:

Maxi-PLS terminal stud,
see brochure Ri4Power Form 2-4, page 103.



Longitudinal connectors

for Maxi-PLS

For simple baying connection of Maxi-PLS
busbars.

Material:
E-Cu

Supply includes:
2 sliding blocks
4 bolts
4 washers
4 spring lock washers
4 nuts

For Maxi-PLS	Packs of	Model No. SV
1600/2000	1	9640.191
3200	1	9650.191

Divider panel module

for Maxi-PLS

For side shielding from neighbouring busbar chambers. In conjunction with the busbar gland and the divider panel, as a preventive measure to prevent arcing.

Material:

PA 6.6

Supply includes:

Assembly parts.



For Maxi-PLS	Number of poles	For enclosure depth mm	Bar centre distance mm	Packs of	Model No. SV
1600/2000	3/4-pole	600	100	1	9640.621
1600/2000	3/4-pole	800	100	1	9640.628
1600/2000	3-pole	600/800	185	1	9640.641¹⁾
3200	3/4-pole	800	150	1	9659.601
3200	3-pole	600	150	1	9650.621
3200	3-pole	600/800	185	1	9650.641¹⁾

¹⁾ For assembly in the rear enclosure section.

Angular connector

for Flat-PLS busbar systems

For connecting horizontal Flat-PLS busbar systems in the rear section to vertical Flat-PLS busbar systems.

Material:

E-Cu



Also required:

See brochure Rittal Ri4Power Form 2-4:

- Contact maker, page 96
- Claw with nut M10, page 104
- Copper castor, page 103
- Busbar claw, page 93
- Screw connections, page 104



For systems	For enclosure depth mm	Bar population up to mm ¹⁾	For conductor	Bracket version mm ²⁾	Packs of	Model No. SV
Flat-PLS 60	600	2 x 60 x 10	L1, L2, L3	3 x 40 x 10	1 set	9675.846
			N	3 x 40 x 10	1 set	9675.847
		4 x 60 x 10	L1, L2, L3	3 x 80 x 10	1 set	9675.886
			N	3 x 80 x 10	1 set	9675.887
	800	2 x 60 x 10	L1, L2, L3	3 x 40 x 10	1 set	9675.848
			N	3 x 40 x 10	1 set	9675.849
4 x 60 x 10		L1, L2, L3	3 x 80 x 10	1 set	9675.888	
		N	3 x 80 x 10	1 set	9675.889	
Flat-PLS 100	600	2 x 100 x 10	L1, L2, L3	2 x 80 x 10	1 set	9675.876
			L1, L2, L3	3 x 100 x 10	1 set	9675.896
		4 x 100 x 10	L1, L2, L3	2 x 80 x 10	1 set	9675.878
			N	2 x 80 x 10	1 set	9675.877
	800	2 x 100 x 10	L1, L2, L3	3 x 100 x 10	1 set	9675.898
			N	3 x 100 x 10	1 set	9675.897
		4 x 100 x 10	L1, L2, L3	3 x 100 x 10	1 set	9675.898
			N	3 x 100 x 10	1 set	9675.897

¹⁾ Number of strands x bar size.

²⁾ Number of angular connectors x bar size.

**More pressure.
Higher air flow rates.**



Assembly without tools

- Straightforward assembly, exchange and maintenance with no need for tools of any kind
- Simple reversal of the air flow direction by turning the fan module
- Individual positioning of the power connection
- Spring clamp terminals for electrical connection without tools
- Latch on louvred grille for fast filter mat replacement without tools



Efficient technology

- Air throughput from 20 to 700 m³/h
- New diagonal fan technology for greater pressure stability and constant air flows in use, even with a contaminated filter mat
- Minimum installation depth
- Flow-optimised air routing
- Extended service life of filter mats and thus longer maintenance intervals



Performance diagram

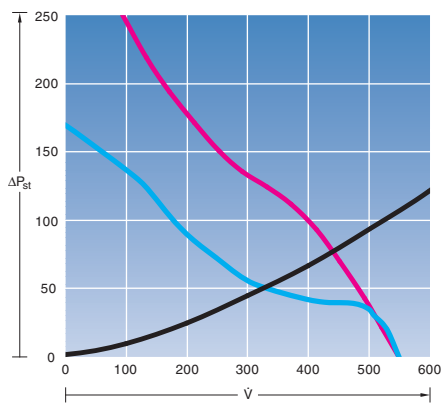

\dot{V} = Volumetric flow (m³/h)
 ΔP_{st} = Stat. pressure difference (Pa)
 — = Resistance curve
 Outlet filter SK 3243.200
 — = old 50 Hz
 Fan-and-filter unit SK 3326.xxx
 — = new 50 Hz
 Fan-and-filter unit SK 3243.xxx

Air routing

- Intelligent symbiosis of radial and axial fan technology
- Air flow spreads diagonally from the fan, promoting a more even air distribution in the enclosure

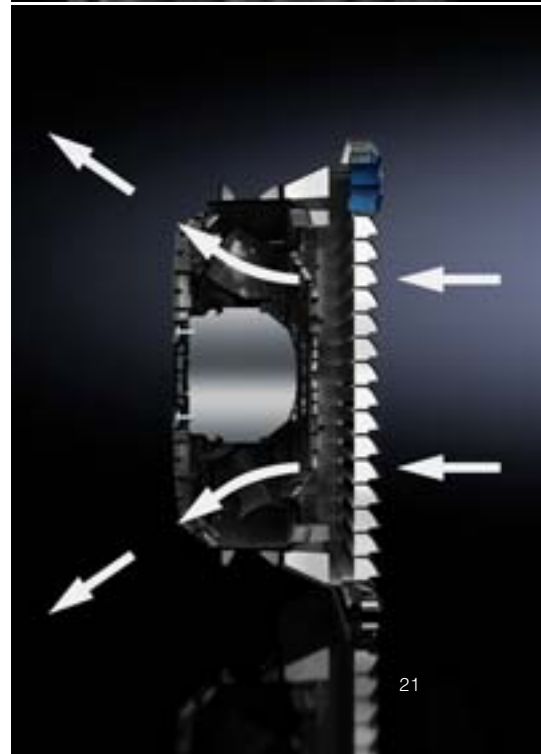

TopTherm fan-and-filter units

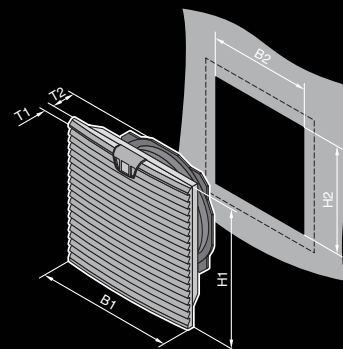

Supply includes:
Complete unit ready to install,
including filter mat.

B = Width
T = Depth

Air throughput 20 – 66 m³/h

Model No. SK fan-and-filter unit	3237.100	3237.110	3237.124	3238.100	3238.110	3238.124
Model No. SK fan-and-filter unit – EMC	3237.600	–	–	3238.600	–	–
Rated operating voltage V, Hz	230, 50/60	115, 50/60	24 (DC)	230, 50/60	115, 50/60	24 (DC)
Dimensions mm	B1/H1	116.5 x 116.5		148.5 x 148.5		
	B2/H2	92 x 92		124 x 124		
	T1	16		16		
Max. installation depth mm	T2	43		58.5		
Air throughput, unimpeded air flow	20/25 m³/h		20 m³/h	55/66 m³/h		55 m³/h
Air throughput with outlet filter including standard filter mat	1 x SK 3237.200: 15/18 m³/h			1 x SK 3238.200: 43/50 m³/h 2 x SK 3238.200: 46/56 m³/h		

Diagonal fan	Self-starting shaded pole motor		DC motor	Self-starting shaded pole motor		DC motor
Rated current	0.065 A/0.052 A	0.14 A/0.12 A	0.14 A	0.12 A/0.11 A	0.24 A/0.23 A	0.28 A
Power consumption	11 W/9 W		3 W	19 W/17 W	19 W/17 W	6 W
Pre-fuse	2 A					
Noise level	38/43 dB (A)		38 dB (A)	46/49 dB (A)		46 dB (A)
Operating temperature range	–15°C to +55°C					
Storage temperature range	–30°C to +85°C					
Colour	RAL 7035					
Protection category to EN 60 529	IP 54 standard IP 55 with additional fine filter mat IP 56 with additional fine filter mat and hose-proof hood					

Model No. SK outlet filter	3237.200			3238.200		
Model No. SK outlet filter – EMC	3237.060	–	–	3238.060	–	–

Accessories	Packs of		
Filter mats	5	3321.700	3322.700
Fine filter mats	5	–	3238.055
Hose-proof hood	1	3237.080	3238.080
Cover panel	1	3237.020	3238.020
Thermostat	1	3110.000	
Temperature indicator	1	3114.200	
Hygrostat	1	3118.000	
Speed control	1	3120.200	

Special voltages available on request. We reserve the right to make technical modifications.

TopTherm fan-and-filter units

Air throughput 105 – 120 m³/h

Model No. SK fan-and-filter unit	3239.100	3239.110	3239.124
Model No. SK fan-and-filter unit – EMC	3239.600	–	–
Rated operating voltage V, Hz	230, 50/60	115, 50/60	24 (DC)
Dimensions mm	B1/H1	204 x 204	
	B2/H2	177 x 177	
	T1	24	
Max. installation depth mm	T2	90	
Air throughput, unimpeded air flow	105/120 m³/h		105 m³/h
Air throughput with outlet filter including standard filter mat	1 x SK 3239.200: 87/100 m³/h 2 x SK 3239.200: 93/108 m³/h 1 x SK 3240.200: 98/111 m³/h		

Diagonal fan	Self-starting shaded pole motor		DC motor
Rated current	0.12 A/0.11 A	0.24 A/0.23 A	0.28 A
Power consumption	19 W/17 W		6 W
Pre-fuse	2 A		
Noise level	46/49 dB (A)		46 dB (A)
Operating temperature range	–15°C to +55°C		
Storage temperature range	–30°C to +85°C		
Colour	RAL 7035		
Protection category to EN 60 529	IP 54 standard/IP 55 with additional fine filter mat/IP 56 with additional fine filter mat and hose-proof hood		

Model No. SK outlet filter	3239.200		
Model No. SK outlet filter – EMC	3239.060	–	–

Accessories	Packs of	
Filter mats	5	3171.100
Fine filter mats	5	3181.100
Hose-proof hood	1	3239.080
Cover panel	1	3239.020
Thermostat	1	3110.000
Temperature indicator	1	3114.200
Hygrostat	1	3118.000
Speed control	1	3120.200

Special voltages available on request. We reserve the right to make technical modifications.

Air throughput 180 – 250 m³/h

Model No. SK fan-and-filter unit	3240.100	3240.110	3240.124	3241.100	3241.110	3241.124
Model No. SK fan-and-filter unit – EMC	3240.600	–	–	3241.600	–	–
Rated operating voltage V, Hz	230, 50/60	115, 50/60	24 (DC)	230, 50/60	115, 50/60	24 (DC)
Dimensions mm	B1/H1	255 x 255				
	B2/H2	224 x 224				
	T1	25				
Max. installation depth mm	T2	107				
Air throughput, unimpeded air flow	180/160 m³/h		180 m³/h	230/250 m³/h		230 m³/h
Air throughput with outlet filter including standard filter mat	1 x SK 3240.200: 138/121 m³/h 2 x SK 3240.200: 165/140 m³/h 1 x SK 3243.200: 165/140 m³/h			1 x SK 3240.200: 183/205 m³/h 2 x SK 3240.200: 203/230 m³/h 1 x SK 3243.200: 203/230 m³/h		

Diagonal fan	Self-starting shaded pole motor		DC motor	Self-starting shaded pole motor		DC motor
Rated current	0.19 A/0.18 A	0.38 A/0.36 A	0.07 A	0.27 A/0.28 A	0.54 A/0.52 A	0.2 A
Power consumption	33 W/33 W		10 W	42 W/46 W	43 W/46 W	25 W
Pre-fuse	2 A	4 A	2 A	4 A		2 A
Noise level	51/46 dB (A)		51 dB (A)	54/56 dB (A)		54 dB (A)
Operating temperature range	–30°C to +55°C					
Storage temperature range	–30°C to +85°C					
Colour	RAL 7035					
Protection category to EN 60 529	IP 54 standard/IP 55 with additional fine filter mat/IP 56 with additional fine filter mat and hose-proof hood					

Model No. SK outlet filter	3240.200					
Model No. SK outlet filter – EMC	3240.060	–	–	3240.060	–	–

Accessories	Packs of	
Filter mats	5	3172.100
Fine filter mats	5	3182.100
Hose-proof hood	1	3240.080
Cover panel	1	3240.020
Thermostat	1	3110.000
Temperature indicator	1	3114.200
Hygrostat	1	3118.000
Speed control	1	3120.200

Special voltages available on request. We reserve the right to make technical modifications.

TopTherm fan-and-filter units

Air throughput 550 – 770 m³/h

Model No. SK fan-and-filter unit	3243.100	3243.110	3244.100	3244.110	3244.140
Model No. SK fan-and-filter unit – EMC	3243.600	–	3244.600	–	–
Rated operating voltage V, Hz	230, 50/60	115, 50/60	230, 50/60	115, 50/60	400/460, 3~, 50/60
Dimensions mm	B1/H1	323 x 323			
	B2/H2	292 x 292			
	T1	25			
Max. installation depth mm	T2	118.5	130.5		
Air throughput, unimpeded air flow	550/600 m³/h		700/770 m³/h		
Air throughput with outlet filter including standard filter mat	1 x SK 3243.200: 465/510 m³/h 2 x SK 3243.200: 508/548 m³/h		1 x SK 3243.200: 544/587 m³/h 2 x SK 3243.200: 614/662 m³/h		

Diagonal fan	1~ capacitor motor				Rotary current motor
Rated current	0.37 A/0.48 A	0.75 A/0.80 A	0.59 A/0.81 A	1.0 A/1.4 A	0.22 A/0.24 A
Power consumption	71 W/89 W	70 W/80 W	109 W/155 W	110 W/156 W	96 W/138 W
Pre-fuse	4 A	6 A	4 A	6 A	Motor circuit-breaker
Noise level	59/61 dB (A)		65/68 dB (A)		
Operating temperature range	–30°C to +55°C				
Storage temperature range	–30°C to +85°C				
Colour	RAL 7035				
Protection category to EN 60 529	IP 54 standard IP 55 with additional fine filter mat IP 56 with additional fine filter mat and hose-proof hood				
Model No. SK outlet filter	3243.200				
Model No. SK outlet filter – EMC	3243.060	–	3243.060	–	–
Accessories	Packs of				
Filter mats	5	3173.100			
Fine filter mats	5	3183.100			
Hose-proof hood	1	3243.080			
Cover panel	1	3243.020			
Thermostat	1	3110.000			
Temperature indicator	1	3114.200			
Hygostat	1	3118.000			
Speed control	1	3120.200			

Special voltages available on request. We reserve the right to make technical modifications.

Conversion table old/new

Output class	20/25 m ³ /h	55/66 m ³ /h	105/120 m ³ /h	180/160 m ³ /h	230/250 m ³ /h	550/600 m ³ /h	700/770 m ³ /h
Cut-out dimensions (old = new)	92 x 92	124 x 124	177 x 177	224 x 224		292 x 292	
24 V	new	3237.124	3238.124	3239.124	3240.124	3241.124	–
	old	3321.027	3322.027	3323.027	3324.027	3325.027	–
230 V	new	3237.100	3238.100	3239.100	3240.100	3241.100	3243.100
	old	3321.107	3322.107	3323.107	3324.107	3325.107	3326.107
115 V	new	3237.110	3238.110	3239.110	3240.110	3241.110	3243.110
	old	3321.117	3322.117	3323.117	3324.117	3325.117	3326.117
400 V	new	–	–	–	–	–	3244.140
	old	–	–	–	–	–	3327.147
EMC fan-and-filter unit, 230 V	new	3237.600	3238.600	3239.600	3240.600	3241.600	3243.600
	old	3321.607	3322.607	3323.607	3324.607	3325.607	3326.607
Outlet filter	new	3237.200	3238.200	3239.200	3240.200	3243.200	
	old	3321.207	3322.207	3323.207	3324.207	3325.207	3326.207
EMC outlet filter	new	3237.060	3238.060	3239.060	3240.060	3243.060	
	old	3321.267	3322.267	3323.267	3324.267	3325.267	3326.267
Hose-proof hood	new	3237.080	3238.080	3239.080	3240.080	3243.080	
	old	3321.800	3322.800	3323.800	3324.800	3325.800	3326.800
Blanking cover	new	3237.020	3238.020	3239.020	3240.020	3243.020	
	old	–	–	–	–	–	–
Standard filter mat (IP 54)	new	3321.700	3322.700	3171.100	3172.100	3173.100	
	old	3321.700	3322.700	3171.100	3172.100	3173.100	3327.700
Fine filter mat (IP 55)	new	–	3238.055	3181.100	3182.100	3183.100	
	old	–	–	3181.100	3182.100	3183.100	3183.100

Accessories for fan-and-filter units

Hose-proof hood

For fan-and-filter units/outlet filters. When the hose-proof hood is mounted above the fan-and-filter unit and outlet filter in conjunction with a fine filter mat, a protection category of IP 56 to EN 60 529 is achieved.

Material:

Stainless steel, silicone

Protection category:

In conjunction with the fan-and-filter units/outlet filters, NEMA 3R + 12 is met.

For fan-and-filter unit	Dimensions mm	Model No. SK
SK 3237. . . .	150 x 230 x 40	3237.080
SK 3238. . . .	176 x 245 x 55	3238.080
SK 3239. . . .	233 x 330 x 55	3239.080
SK 3240. . . /SK 3241. . . .	282 x 390 x 85	3240.080
SK 3243. . . /SK 3244. . . . SK 3245. . . .	350 x 480 x 110	3243.080



Blanking cover

If existing mounting cut-outs for fan-and-filter units/outlet filters need to be closed to achieve a higher protection category, the filter mat of the fan-and-filter unit/outlet filter can simply be replaced with a blanking cover; welding or other mechanical modification of the enclosure is not necessary.

Material:

Plastic

Protection category:

IP 55

For fan-and-filter unit	Model No. SK
SK 3237. . . .	3237.020
SK 3238. . . .	3238.020
SK 3239. . . .	3239.020
SK 3240. . . /SK 3241. . . .	3240.020
SK 3243. . . /SK 3244. . . . SK 3245. . . .	3243.020



Spare filter mats

Made of chopped-fibre mat with a progressive structure. Temperature-resistant to 100°C, self-extinguishing category F1 to DIN 53 438. Dust-laden air side: Open structure
Clean air side: Closed structure
Reliable filtering of virtually all types of dust from a particle size of 10 µm.

Material:

Chemical fibre

For fan-and-filter unit	Filter class to DIN EN 779	Model No. SK
3237. . . .	G2	3321.700
3238. . . .	G2	3322.700
3239. . . .	G3	3171.100
3240. . . /3241. . . .	G3	3172.100
3243. . . /3244. . . .	G3	3173.100



Fine filter mats

Made of chopped-fibre mat with a progressive structure. Temperature-resistant to 100°C, self-extinguishing category F1 to DIN 53 438. Dust-laden air side: Open structure
Clean air side: Closed structure
Reliable filtering of virtually all types of dust up to a particle size of 10 µm.

Material:

Chemical fibre

For fan-and-filter unit	Filter class to DIN EN 779	Model No. SK
3238. . . .	F5	3238.055
3239. . . .	F5	3181.100
3240. . . /3241. . . .	F5	3182.100
3243. . . /3244. . . .	F5	3183.100



TopTherm chillers



Control module

- One version for two frequencies 400 V/50 Hz, 460 V/60 Hz
- Temperature control by way of fixed or differential values, switchable

Chiller module

- Air intake at rear, optionally also on left or right for the 8, 12 and 16 kW versions
- Refrigerant R410A
- Simple exchanging of modules with different outputs

Water module

- Water bypass as standard
- Flow monitor as standard
- Simple exchanging of modules of different capacities



TopTherm chillers

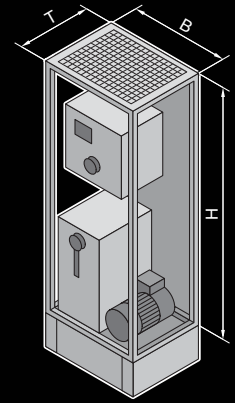

Benefits:

- Modular design
- Small footprint
- Convenient servicing
- High reliability thanks to standard water bypass

- One version for two frequencies = international compatibility
- Series product available from stock
- Fast delivery, as pre-assembled modules can simply be combined into a recooling system

Supply includes:

Complete unit ready for connection.

B = Width
T = Depth

Photo shows a configuration example with equipment not included in the scope of supply.

Cooling output 8 – 40 kW

Model No. SK	3335.600	3335.610	3335.620	3335.630	3335.640	3335.650	3335.660
Rated operating voltage V, Hz	400, 3~, 50 Hz/460, 3~, 60 Hz						
Dimensions mm	W	805			1205	1610	2410
	H	2000			2000	2000	2000
	D	805			805	805	805
Cooling output¹⁾ at T_w = 10°C/T_u = 32°C	6.9/7.6 kW	10.3/11.3 kW	13.8/15.2 kW	17.2/18.9 kW	21.6/23.8 kW	27.6/30.4 kW	34.5/38 kW
Cooling output¹⁾ at T_w = 18°C/T_u = 32°C	8/8.8 kW	12/13.1 kW	16/17.6 kW	20/21.8 kW	25/27.6 kW	32/35.2 kW	40/44 kW
Power consumption max. kW	3.4/4.0	5.9/6.4	6.7/8.0	8.0/9.9	10.5/12.9	13.5/15.9	16.0/19.8
Rated current max. A	6.4/5.7	8.2/9.5	11.1/11.3	15.9/13.9	20.3/20.7	22.2/22.6	31.7/27.9
Refrigerant	R410A						
Number of cooling circuits	1					2	
Temperature range – environment	+10°C to +43°C						
Temperature range – water	+7°C to +25°C						
Pump capacity at 2.5 bar (l/min.) 50/60 Hz	35/70		30/85		50/140		60/40 (at 60 Hz 3.7 bar)
Tank capacity l	80			135			
Water connections	1"					1 1/4"	
Weight (empty) kg	250	270	325	470	500	580	940
Colour	RAL 7035						
Protection category (electrics)	IP 44						
Temperature control	Microcontroller control (factory setting +18°C, differential value control also possible)						
Accessories	Packs of						
Air filter	1	3286.530			3286.540		3286.530 ²⁾ 3286.540 ²⁾
Levelling feet	4	7493.100					
Levelling feet with vibration dampening	4	7493.230					
Base/plinth components front and rear	100 mm	8601.805					
	200 mm	8602.805					
Base/plinth trim panels, side	100 mm	8601.085					
	200 mm	8602.085					
Rifrost	Canister	10 l	3301.960				
		25 l	3301.965				
		200 l	3301.967				

Technical modifications reserved.

¹⁾ Without pump heat losses.

²⁾ 2 packs

Enclosure heaters



Fast assembly

- Snap-fastening onto 35 mm support rails EN 50 022
- Direct screw-fastening onto the mounting plate



Energy-efficient design

- PTC technology
- Computational Fluid Dynamics (CFD)-assisted design for superior heating performance with the same construction size



Output range

- without fan
10, 20, 30, 50, 75, 100, 150 W
- with fan
250, 400, 800 W



Enclosure heaters

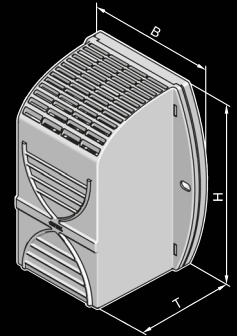
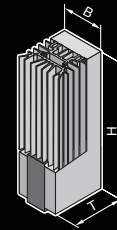

Supply includes:

PTC heater with quick-fit terminal and assembly parts.

Note:

- Thermostat SK 3110.000 (see accessories) is recommended for precise temperature control in the enclosure.
- In order to prevent condensation on assemblies, hygrostat SK 3118.000 (see accessories) is recommended to regulate heating.
- In larger enclosures, even heat distribution is best achieved by installing several low-output heaters.
- The installation of heaters is generally advisable, even when using heat exchangers and cooling units, in order to prevent condensation.

B = Width
T = Depth

Without fan, continuous thermal output 10 – 150 W

Model No. SK		3105.310	3105.320	3105.330	3105.340	3105.350	3105.360	3105.370
Dimensions mm	W	45	45	64	64	64	90	90
	H	120	120	155	155	230	165	180
	D	46	46	56	56	56	75	75
Rated operating voltage V, Hz		110 – 240 V, 50/60 Hz						
Continuous thermal output at $T_u = 10^\circ\text{C}$		8 – 10 W	18 – 20 W	23 – 30 W	49 – 50 W	63 – 75 W	86 – 100 W	130 – 150 W
Pre-fuse T		2 A		4 A				
Accessories		Packs of						
Thermostat	1	3110.000						SK Cat. (hardcover), page 178
Hygrostat	1	3118.000						SK Cat. (hardcover), page 178
Temperature indicator/controller	1	3114.200						IN 2010, page 33

Special voltages available on request. We reserve the right to make technical modifications.

With fan, continuous thermal output 250 – 800 W

Model No. SK 110 V		3105.210	3105.220	3105.230
Model No. SK 230 V		3105.180	3105.190	3105.200
Dimensions mm	W	142	142	142
	H	170	170	170
	D	101	101	101
Rated operating voltage V, Hz		110 or 230 V, 50/60 Hz		
Continuous thermal output at $T_u = 10^\circ\text{C}$		250 W¹⁾	400 W¹⁾	800 W¹⁾
Pre-fuse gG for 110 V		4 A	6 A	10 A
Pre-fuse gG for 230 V		4 A	6 A	6 A
Accessories		Packs of		
Thermostat	1	3110.000		SK Cat. (hardcover), page 178
Hygrostat	1	3118.000		SK Cat. (hardcover), page 178
Temperature indicator/controller	1	3114.200		IN 2010, page 33

¹⁾ Output with fan.

Special voltages available on request. We reserve the right to make technical modifications.

Thermoelectric cooler

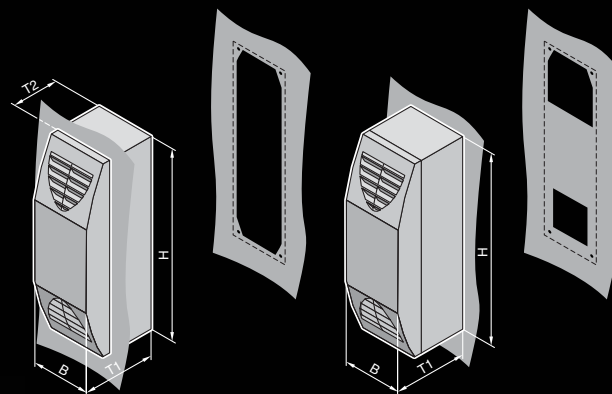

Now also with heater function

Application:

- Ideal for climate control of small enclosures and command panels.
- Especially suitable for use on support arm systems.
- Optimum space utilisation.
- Targeted cooling of hotspots and heating where necessary.

Supply includes:

Thermoelectric climate control unit, wired ready for connection, with multilingual documentation, mounting accessories and parameterisation software.

Detailed drawing,

available on the Internet.

Performance diagrams,

available on the Internet.

B = Width
T = Depth

Useful cooling/heating output 100 W

Model No. SK	3201.200	3201.300
Dimensions in mm	B 125 H 400 T1 155	
Installation depth	T2 100	
Rated operating voltage V, Hz	100 – 230 V, 50/60	24 V DC
Start-up current	0.7 A	4.5 A
Rated current	0.7 A	4.5 A
Refrigeration factor/COP	L 35 L 35 1.0	1.2
Useful cooling output \dot{Q}_k to DIN 3168	L 35 L 35 100 W	100 W
Thermal output	200 W	200 W
Power pack integrated	■	–
Colour of cover/unit	RAL 7024/Anodised aluminium	
Protection category	IP 54	
Weight	3.0 kg	2.5 kg
Temperature range	–30°C to +55°C	–30°C to +60°C
Air throughput, unimpeded air flow	50 m ³ /h	
Type of connection	Plug-in spring connection terminal	
Pre-fuse gG	2 A	10 A
Accessories	Packs of	SK Cat. (hardcover), page
Power pack 240 W for 35 mm top-hat rail	1 –	3201.040 –
Filter mat	1 3201.050	191
Digital temperature indicator	1 3114.200/3114.115	177
Master/slave adaptor	1 3201.070	–
Condensate hose, 5 m length	1 3301.606	–

We reserve the right to make technical modifications. Special voltages available on request.

CS Outdoor climate control



For roof mounting

With microcontroller¹⁾ and 400 W heater as standard.

Mounting frame:

Required for CS 9762.212.

For wall mounting

With microcontroller¹⁾ and 400 W heater as standard.

For partial installation

With microcontroller¹⁾ and 800 W heater as standard.

Installation options:



- in the door or rear panel
- in the side panel

Protection category:

IP 55 to EN 60 529 (internal circuit to external circuit)

¹⁾ Units with Comfort controller. The Comfort controller is installed on the inside of the cooling units, and is not accessible from the outside.

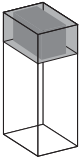
Cooling units for CS modular enclosures and Toptec

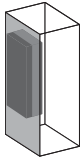
			
Model No. CS	9762.212	9761.212	9768.152
Installation	Roof mounting	Wall mounting	Partial internal mounting
Rated operating voltage	AC 230 V, 50/60 Hz		
Unit dimensions in mm	W 535 H 390 D 400	515 1170 152	400 1050 310
Minimum enclosure dimensions in mm	W x D 600 x 500	W x H 600 x 1200 mm	W/D x H 600 x 1200
Useful cooling output \dot{Q}_K to DIN 3168	L 35 L 35 L 35 L 50	900 W/1020 W 720 W/780 W	1500 W/1600 W 1250 W/1250 W
Heater	400 W	400 W	800 W
Rated current max.	4.0 A	4.2 A	5.8 A
Start-up current max.	10.6 A	8.3 A	19.0 A
Power consumption P_{el} to DIN 3168	L 35 L 35 L 35 L 50	460 W/570 W 520 W/655 W	605 W/790 W 690 W/880 W
Coolant	R134a	550 g	600 g
p. max.	26 bar	24 bar	28 bar
Temperature range	-33°C to +55°C		
Air throughput of fans – unimpeded air flow	Internal circuit fan External circuit fan	570 m ³ /h 570 m ³ /h	880 m ³ /h 880 m ³ /h
Type of connection	Plug panel		
Weight	29 kg	45 kg	40 kg
Material (enclosure)	Aluminium	Sheet steel	Aluminium
Surface finish	Spray-finished in RAL 7035, pure polyester		
Accessories			
Mounting frame	9765.051	–	–

Delivery times available on request. The partially internally mounted CS 9768.152 may be inserted directly. Cooling units are manufactured to order. The units are assembled and supplied connected to the modular or Toptec enclosure. Roof-mounted cooling units may only be used in the modular enclosure. Adaptations to other enclosure platforms are available on request.

Digital enclosure internal temperature display and thermostat

For installation on the enclosure door or wall.

Technical specifications:

- 2 voltage ranges for 100 – 230 V, 50/60 Hz and 24 – 60 V (DC)
- Dimensions (W x H x D): 74.5 x 39 x 98 mm
- Three-digit, 7-segment display
- Can be switched from °C/°F
- Temperature range: +5°C to +55°C
- Includes 1800 mm long NTC sensor
- Two relay outputs as change-over contact and normally open contact (maximum contact load 230 V, 6 A)
- Freely selectable switching difference
- The freely adjustable setpoint values can be set using the membrane keyboard at the front
Setting range: +5°C to +55°C
- Display and switching accuracy +/- 2 K
- Mounting cut-out 68 x 33 mm.
- The minimum and maximum recorded temperatures are stored until it is next reset

Packs of	Model No. SK
1	3114.200

Special requirements can be accommodated on request.



Speed control

Temperature-dependent speed control for Rittal fan-and-filter units and air/air heat exchangers for noise reduction and to save energy in part-load operation.

Technical specifications:

- For mounting on a 35 mm support rail DIN EN 50 022
- Dimensions (W x H x D): 105 x 90.5 x 60.2 mm
- Rated operating voltage: 100 – 230 V AC
- Setting range: +20°C to +55°C
- Phase cross-over with microcontroller
- Maximum fan output 300 W or 2 A

Packs of	Model No. SK
1	3120.200

Supply includes:

Speed control, NTC sensor, length 1.80 m.



Therm 6.0 software

Rittal Therm 6.0 is a calculation program for enclosure climate control.

- New layout in Vista style with semi-transparent windows
- Improved user guidance via tabs and simple selection menus
- Express and expert versions
- Identification of units with heat loss via a tree structure
- Key calculation data is visible at all times
- Simultaneous selection of wall-mounted and roof-mounted units
- Internet updates

The Therm 6.0 software package takes care of the complex calculation of climate control requirements. A user-friendly interface guides the operator to the most suitable, correctly dimensioned climate control component. All evaluations are closely based on the requirements of IEC/TR 60 890 AMD 1/02.95 and DIN 3168 for enclosure cooling units.

Packs of	Model No. SK
1	3121.000

Supply includes:

CD-ROM, with 19 languages.

Note:

Your free 30-day trial version may be downloaded at www.rittal.com



Server racks

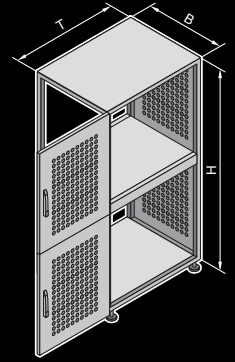

Design features

- Robust frame structure
- Front and rear door fully vented; vented surface area > 78% perforated
- 2-point locking
- Door hinge may be swapped to opposite side
- Cable entry via the base/plinth and roof (optional)
- Bayable at all levels
- Static load capacity of up to 1000 kg

Material:

Sheet steel

Surface finish:

Enclosure frame: Dipcoat-primed
Enclosure panels: Dipcoat-primed, powder-coated in RAL 7035
Mounting angles and punched sections with mounting flanges: Zinc-plated, passivated

Supply includes:

Enclosure frame TS 8 with sheet steel doors front and rear, vented, with 180° hinges, L-shaped, depth-variable fitted mounting angles, levelling feet, comfort handle for semi-cylinder with security lock 3524 E and 2-point lock.

Detailed drawing,

available on the Internet.

Photo shows a configuration example with equipment not included in the scope of supply.

Based on Rittal TS 8, pre-configured

Number of front and rear doors		2	4
U		2 x 21	4 x 10
Width (B) mm		600	600
Height (H) mm		2200	2200
Depth (T) mm		1000	1000
Model No. DK as bayed enclosure without side panels, without baying kit	RAL 7035	7831.453¹⁾	7831.463¹⁾
Doors			
Sheet steel doors, vented, front and rear		■	■
Roof			
Solid roof plate		■	■
Roof plate for side cable entry		7526.607	7526.607
Base			
Levelling feet		■	■
Interior installation			
482.6 mm (19") levels front and rear		■	■
L-shaped mounting angles		■	■
Mounting angles attached to depth stays		■	■
Panel earthing, fitted		■	■
Individual compartments, shielded/separate cable routing per compartment		■/■	■/■
Accessories			
Removable side panels with T lock, IP 20	RAL 7035	7824.220	7824.220
Security lock 3524 E for side panels		7824.500	7824.500
Base assembly bracket		8800.210	8800.210
Depth-variable slide rail, 1 U		7063.883	7063.883
Stabiliser, pull-out		7825.250	7825.250

■ Included with the supply.

¹⁾ Delivery times available on request.

Modular Safe

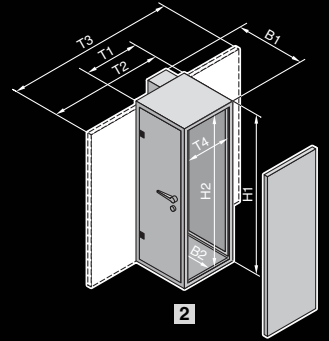
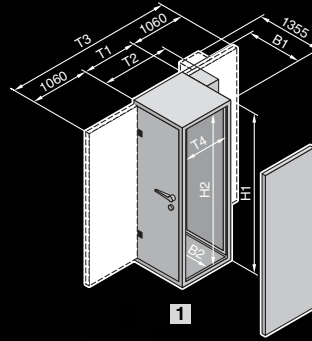

The Modular Safe Extend offers ultimate security and efficient protection against potential physical threats. Available in a variety of sizes, it permits free configuration in respect of the doors and locking systems, cable bulkheads and climate control solutions.

Protection standards

- Fire protection F90
- Compliance with limit values 50 K ΔT and 85% relative humidity for 30 minutes
- Burglar resistance class WK4
- Protection against smoke gases
- Protection against dust and water jets

All tests were performed as system tests and confirmed by way of test reports.

Colour:
Enclosure: RAL 7035

The Modular Safe promises a dependable basic level of protection, particularly for locations which place lesser demands on physical security. It is available in both 47 U and 33 U versions, each with a wide range of configuration options. Thanks to its reduced weight, the Modular Safe is also suitable for locations with a limited floor load-bearing capacity.

Protection standards

- Fire protection F30
- Burglar resistance class WK2
- Protection against smoke gases
- Protection against dust and water jets

The tests were performed as system tests and confirmed by way of test reports.

Colour:
Enclosure: RAL 7035

Photo shows a configuration example with equipment not included in the scope of supply.

Modular Safe

U		1 Modular Safe Extend				2 Modular Safe			
		42	47	42	47	33	47	33	47
External dimensions (mm)	Width (B1)	1100	1100	1100	1100	1500	1500	1500	1500
	Height (H1)	2210	2410	2210	2410	1942	2321	1942	2321
	Depth (T1)	1200	1200	1400	1400	1238	1238	1238	1238
	Depth (T2)	1520	1520	1720	1720	2280	2280	2280	2280
	Depth (T3)	3324	3324	3524	3524	3322	3322	–	–
Internal dimensions (mm)	Width (B2)	920	920	920	920	979 ¹⁾	979 ¹⁾	979 ¹⁾	979 ¹⁾
	Height (H2)	2030	2230	2030	2230	1840	2219	1840	2219
	Depth (T4)	1000	1000	1200	1200	1010	1010	1010	1010
Clear height of door opening (mm)		–	–	–	–	1678	2057	1678	2057
Model No.		7999.931	7999.932	7999.983	7999.987	823026	820570	822927	823013

¹⁾ With heat exchanger installed

Standard protection from:



Fire



Extinguishing water



Corrosive gases



Vandalism



Unauthorised access



Dust



Theft/burglary

Basic Safe Compact

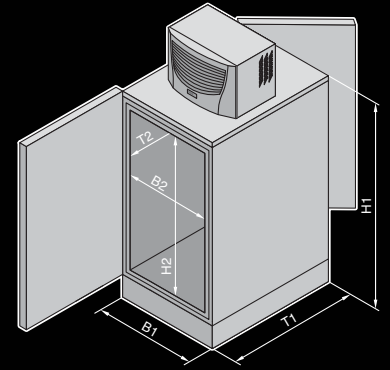

Supply includes:

- Security enclosure with operating and service doors (three-point locking)
- Cable entry in both side elements
- Cooling capacity 1.3/2.4 kW
- Usable height for installations 15 U

Compatible configuration:

- Early fire detection system – EFD Plus
- Fire alarm and extinguisher system DET-AC Plus
- Monitoring – CMC-TC
- Uninterruptible power supply – PMC 12
- 19" server rack

Applications:

- Micro data centre for small companies
- Protection for servers, storage applications, ...
- Suitable for integration into smaller office rooms
- Storage of personal data, e.g. doctors' surgeries or tax advisors

Protection standards:

- Fire protection F90 to DIN 4102
 - Compliance with limit values $\Delta T < 50$ K, relative humidity $< 85\%$ for 10 minutes
 - Tested burglary protection WK II
 - Protection against dust and water jets IP 55
- The tests were performed as system tests and confirmed by way of test reports.

Colour:

Enclosure: RAL 7035

Photo shows a configuration example with equipment not included in the scope of supply.

Basic Safe Compact

Model No.	110010399800	110010399600
Cooling capacity kW	1.3	2.4
Width (B1) mm	806	806
Height (H1) mm	1646	1699
Depth (T1) mm	1319	1319
Clearance width (B2) mm	620	620
Clearance height (H2) mm	827	827
Clearance depth (T2) mm	1024	1024
Weight kg	330	360
19" rack		
Model No. DK	7995.992	7995.992
U	15	15
Depth mm	1000	1000

Standard protection from:



Fire



Extinguishing water



Vandalism



Unauthorised access



Dust



Theft/burglary

Data Centre Container DCC

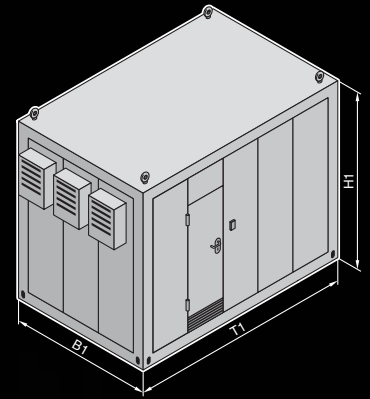

Benefits:

- PUE (Power Usage Effectiveness) below 1.2
- Innovative direct free cooling saves energy
- Highly efficient UPS
- Up to 329 U (7 racks) and max. 6 kW/rack
- Deliver – connect up (data and power) – ready to use
- Monitor and manage the infrastructure (RiZone)
- All-in-one concept, no additional external installations
- Simple planning – fixed price for data centre
- Autonomy time: Min. 15 minutes

Technical specifications:

Container:

- Fire protection to EN 1363/ DIN 4102: F30, optionally F90, type-tested
- Burglar resistance to EN 1627/1630 resistance class WK2, optionally WK3

Bulkhead system:

- Type: Hard bulkhead DN200
- Dimensions of packing space: 120 x 120 mm

Climate control – direct free cooling:

Available with 7 and 10 kW units. Up to 3 units can be integrated.

Technical data of 7 kW unit:

- Type: RDF – Rittal Direct Free-cooling
- Useful cooling capacity (tA 32°C, RH 40%): 7.0 kW
- Max. outdoor temperature: +40°C
- Min. outdoor temperature: -35°C
- Refrigerant: R407c
- Filter grade: F 7
- Unit dimensions (W x H x D): 780 x 2370 x 325 mm
- Sound pressure level, A-weighted, 5 m from external unit, free field: 40 dB (A)

Raised floor:

- Substructure type: Control room
- Number of slotted plates dependent on number of racks
- Total raised height: 300 mm

Power distribution:

- Infeed: Wall-mounted CEE connector, 125 A, 3-phase/N/PE, 400 V/50 Hz
- Enclosure dimensions (W x H x D): 600 x 2000 x 400 mm

Photo shows a configuration example with equipment not included in the scope of supply.

Data Centre Container DCC

Width (B1) mm	3000
Height (H1) mm	3250
Depth (T1) mm	6055
Clearance width (B2) mm	2664
Clearance height (H2) mm	2896
Clearance depth (T2) mm	5722
Useful area	15.2 m ²
Model No.	Project planning on request

Complete infrastructure



Fire alarm and extinguisher system DET-AC XL

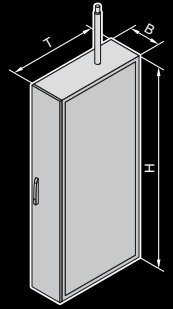

Benefits:

- Extinguisher system for room volumes up to 84 m³
- Rack extinguisher system for up to 24 racks
- Suitable for incorporation into TS 8 server rack suites
- Integration into the RimatriX5 concept
- Simple project planning on the basis of standard packages
- Innovative extinguisher gas NOVEC 1230
 - Eco-friendly
 - Uncritical for IT components

Three solutions are available in the standard version:

Extinguishing for:

- up to 8 racks
- up to 16 racks
- up to 24 racks

In addition, Rittal is able to configure both room and rack extinguisher systems to your individual specifications.

Function principle:

The detection system of the DET-AC XL draws room or rack air in continuously and detects even the tiniest smoke particles during the initial phase of a fire, the pyrolysis phase. After a defined delay time, the extinguisher gas bottle is opened electrically and the gas flows out into the room or racks via the extinguisher nozzles.

Photo shows a configuration example with equipment not included in the scope of supply.

Fire alarm and extinguisher system DET-AC XL	S-08-40-10	S-16-40-10	S-24-40-10	S-08-40-12	S-16-40-12	S-24-40-12
Width (B) mm		300			300	
Height (H) mm		2000			2000	
Depth (T) mm		1000			1200	
Model No.	7338.160	7338.161	7338.162	7338.163	7338.164	7338.165
Accessories						
Nozzle piping kit for extinguisher system						7338.166
Piping kit for smoke extraction system						7338.167
Nozzle piping kit for extinguisher system between enclosure suites						7338.168
Piping kit for smoke extraction system between enclosure suites						7338.170
Pressure relief flap for enclosures						7338.171



Monitor/keyboard unit, 1 U



Benefits:

- High-quality manufacturing
- Analog and digital video input
- Separate numerical keypad
- Optionally with integrated KVM switch for up to 32 server connections in just 1 U
- With 17" TFT display and VGA/DVI connection
- Low energy consumption
- Simple, one-man installation

Technical design²⁾

- 17" (432 mm) TFT display
- Native resolution 1280 x 1024
- Format 4 : 3
- 16.7 million colours
- Brightness approx. 350 cd/m² (typ.)
- Contrast ratio approx. 1000 : 1
- Mains voltage 100 – 240 V AC, 50 – 60 Hz
- Ambient temperature +5°C to +45°C (in operation)

- Max. power consumption in operation, without optional KVM switch: 32 W
- Max. power consumption when closed, without optional KVM switch: < 1 W
- Rear connections: Mains power, VGA, DVI-D, PS/2, USB, power supply for KVM

Photo shows a configuration example with equipment not included in the scope of supply.

With 17" TFT display and VGA/DVI connection

Width mm				448
Height U				1
Depth mm				680
Keyboard		Packs of	German	English
Model No. DK	RAL 7035	1	9055.310	9055.312
	RAL 9005	1	9055.410¹⁾	9055.412¹⁾

Other country-specific versions available on request.

¹⁾ Extended delivery times.

²⁾ We reserve the right to make changes in line with technical progress.



Monitor/keyboard unit, 17", native resolution 1280 x 1024



To be able to access further servers, the monitor/keyboard unit can be combined with one of the Rittal KVM switches SSC view 8 USB or SSC view 32 Cat. (KVM model nos.: DK 7552.002, DK 7552.100)



Rear connections:
Mains power, VGA, DVI-D, PS/2, USB, power supply for KVM.

UPS PMC 12 compact

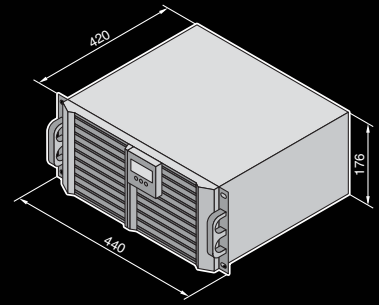

The PMC 12 UPS is distinguished by its use of double-conversion topology. Double-conversion technology provides the basis for an optimum supply voltage to all connected loads.

This makes the Rittal PMC 12 compact UPS ideally suited for all applications in the IT environment and for other requirements such as automation technology, system control etc. A scalable autonomy of up to 29 minutes at 100% load produces a broad application spectrum.

Supply includes:

Single-phase UPS systems with internal "hot-swap compatible" batteries, assembly parts, operating manual, software on CD-ROM, USB, RS232 cable and earthing-pin connection cable.



Also required:

Country-specific connection cables are required to operate the UPS systems.

Photo shows a configuration example with equipment not included in the scope of supply.

Single-phase, output range 2 – 3 kVA

UPS for 482.6 mm (19") racks or as floor-standing enclosures		UPS with integral battery	
Model No. DK PMC 12 compact, 4 U		7857.482	7857.483
Width x height mm		440 (19") x 176 (4 U)	
Depth ¹⁾ mm		420	420
Weight kg		26	27
Power	VA	2000	3000
	Watts	1600	2400
	Max. heat loss (W)	210	252
Input	Rated voltage	230 V (160 – 288 V)	
	Frequency	50/60 Hz ±5%	
	Power factor	> 0.99 with linear load	
Output	Voltage	230 V ≤ ±1% (200/208/220/230/240 V adjustable)	
	Frequency, synchronised	±1 Hz	
	Efficiency, AC mode	88%	90%
	Power factor	0.8	
Battery 5 years EUROBAT	Autonomy at 100% load in the delivered state	≥ 7 min.	≥ 5 min.
	1 additional battery pack	≥ 17 min.	≥ 12 min.
	2 additional battery packs	≥ 29 min.	≥ 20 min.
Communication	Interface	1 x USB, 1 x RS232	
	SNMP	Optional network monitoring card DK 7857.420/relay card 7857.410	
	Operating systems supported	Windows, Unix, Linux, Novell, Apple; RCCMD shutdown licence DK 7857.421	
	Emergency Power Off (EPO)	■	
Connection	Input connection 230 V	10 A C14	16 A C20
	Output connection 230 V	6 x 10 A, C13, 2 units switched	4 x 10 A, C13, 2 units switched, 1 x 16 A, C19
Standards and certifications	Power	IEC/EN 62 040-3	
	EMC	EN 50 091-2/EN 62 040-2 class A, EN 61 000-4-2/-3/-4/-5/-6-8/-11, EN 61 000-3-2/-3	
	Labelling	CE, FCC	
Accessories			
Battery pack PMC 12 compact		7857.488	7857.488
Connection cable at output end, UPS, single-phase, for PSM busbar		7856.027	7856.030

¹⁾ Without an external battery pack

PSM/PCU system

PSM/PCU modules

Individual current measurement per slot

Features of the active PSM/PCU modules in conjunction with the CMC-TC

- 2-digit local LED 7-segment current display for total current values.
- Individual current measurement per slot with limit configuration via CMC-TC web interface.
- LED colour code for load assessment per module/slot.
- SNMP switching option via the network.
- Up to 16 modules via a joint web interface under one IP address.
- Monitoring of the current per module and outgoing slot.
- Limits may be freely configured.
- The 8 individual slots of the module may be switched separately in conjunction with the CMC-TC. May also be linked to other CMC-TC alarm messages.
- Alarm messages are additionally indicated by flashing LEDs.

PSM plug-in module/19" PCU

Modules for the Rittal PSM busbar system or for mounting on either the 19" level or enclosure frame. In conjunction with Rittal CMC-TC, the managed modules offer further convenient functions. These include event-controlled switching of the outputs and current measurements for individual sockets.

The switchable modules also feature sequential reconnection after a power failure. Versions are available for all the important connector types used in the data centre.

Note:

A PSM busbar (e.g. 7856.020) is required to be able to use the PSM modules. Corresponding information can be found in Rittal Catalogue 32, from page 789.

A CMC-TC system is required for control and remote monitoring of the managed modules via TCP/IP. The CMC Processing Unit permits the administration of up to 16 modules. Corresponding information can be found in Rittal Catalogue 32, from page 809.

All relevant information is also to be found on the Internet at: www.rittal.com

Model No. DK	Type/slots on PSM busbar	Designation/pin pattern	Number of slots	Switchable outputs	Administration via IP/SNMP	Individual current measurement
7859.120	PSM plug-in module/ 1 slot	IEC 60 320 C13	6	no	no ¹⁾	no ²⁾
7859.130	PSM plug-in module/ 1 slot	IEC 60 320 C19	4	no	no ¹⁾	no ²⁾
7859.212	PSM plug-in module/ 2 slots	Earthing-pin/C13	4/2	yes	yes	yes
7859.222	PSM plug-in module/ 2 slots	IEC 60 320 C13	8	yes	yes	yes
7859.232	PSM plug-in module/ 2 slots	IEC 60 320 C19/C13	4/2	yes	yes	yes
7859.215	PCU 19" mounting	Earthing-pin/C13	4/2	yes	yes	yes
7859.225	PCU 19" mounting	IEC 60 320 C13	8	yes	yes	yes
7859.235	PCU 19" mounting	IEC 60 320 C19/C13	4/2	yes	yes	yes

¹⁾ Fixed limit values 7 A/13 A

²⁾ Individual current measurement per module

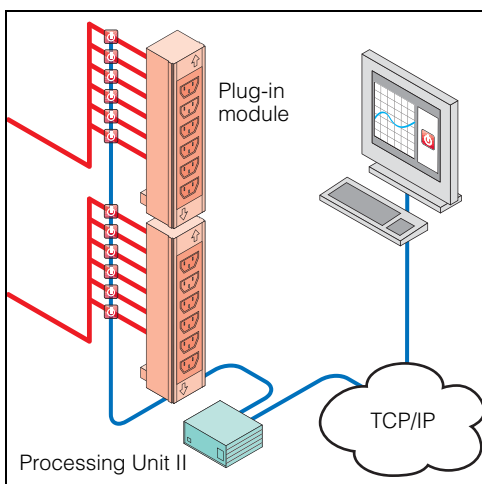

Ingeniously simple: Optical load indicators

An immediate overview of phase loads at all times. No more worries about unnoticed overloading or unbalanced power distribution in the rack.

Photo shows a configuration example with equipment not included in the scope of supply.

System accessories



Comfort handle

with door opener function

By pressing the lock mechanism, the door is released by the automatic door opening system. Prepared for the installation of standard commercially available semi-cylinders with an overall length of 40 mm to DIN 18 252, see Innovations 2010, page 42, and SZ lock inserts and push-button inserts, see Catalogue 32, page 948.

Length: 302 mm.

To fit Automatic door control unit (DK 7320.790) with installed Automatic door kit (DK 7320.792/.795/.796).

Technical specifications:

Rated voltage: 24 V DC

Rated current: Max. 3 A

Connection cable: Length 3 m

Temperature application range: +5°C to +40°C

Version	Model No. DK
RAL 7035	7320.794



Also required:

Handle adaptor for mounting on glazed door TS, Model No. TS 8611.080, see Cat. 32, page 934.



Semi-cylinder

to DIN 18 252

40 mm, for individual locks in handle systems with cylinder insert.

Supply includes:

3 keys per semi-cylinder.

Semi-cylinder	Model No. CS
1	9785.040
2 ¹⁾	9785.042

¹⁾ Simultaneous locking within the same pack, no simultaneous locking for different packs.



RiZone Management Pack

for Microsoft System Center Operations Manager

The transparent representation of the data centre infrastructure managed by RiZone facilitates a new, comprehensive view of data centre operations, with logical allocation of the physical infrastructure to an application that is available to a server.

Benefits:

- Representation of the data centre's efficiency
- Increased availability thanks to optimised planning foundations
- Calculation of consumption figures down to a single server
- Energy optimisation with a simultaneous increase in availability

Microsoft®
GOLD CERTIFIED

Partner

Because Rittal is a member of the Microsoft System Center Alliance, customers have access to an entire network of customised solutions covering every aspect of RiZone and SCOM.

List of model numbers/Index

Model No.	Page	Model No.	Page	Model No.	Page	Model No.	Page	Model No.	Page
1670.600	11	3237.080	25	3243.200	24	7338.165	38	9640.641	19
1671.600	11	3237.100	22	3243.600	24	7338.166	38	9649.160	18
1672.600	11	3237.110	22	3244.100	24	7338.167	38	9650.021	18
1674.600	11	3237.124	22	3244.110	24	7338.168	38	9650.031	18
1675.600	11	3237.200	22	3244.140	24	7338.170	38	9650.171	18
2400.900	9	3237.600	22	3244.600	24	7338.171	38	9650.181	18
2400.910	9	3238.020	25	3321.700	25	7831.453	34	9650.191	18
2400.920	9	3238.055	25	3322.700	25	7831.463	34	9650.621	19
2400.930	9	3238.060	22	3335.600	27	7856.027	40	9650.641	19
2400.940	9	3238.080	25	3335.610	27	7856.030	40	9659.160	18
2400.950	9	3238.100	22	3335.620	27	7857.482	40	9659.601	19
2400.960	9	3238.110	22	3335.630	27	7857.483	40	9675.846	19
2400.970	9	3238.124	22	3335.640	27	7857.488	40	9675.847	19
3020.500	13	3238.200	22	3335.650	27	7859.120	41	9675.848	19
3105.180	30	3238.600	22	3335.660	27	7859.130	41	9675.849	19
3105.190	30	3239.020	25	6070.000	6	7859.212	41	9675.876	19
3105.200	30	3239.060	23	6070.200	6	7859.215	41	9675.877	19
3105.210	30	3239.080	25	6071.200	6	7859.222	41	9675.878	19
3105.220	30	3239.100	23	6071.400	6	7859.225	41	9675.886	19
3105.230	30	3239.110	23	6071.600	8	7859.232	41	9675.887	19
3105.310	30	3239.124	23	6071.800	6	7859.235	41	9675.888	19
3105.320	30	3239.200	23	6072.000	6, 8	7995.992	36	9675.889	19
3105.330	30	3239.600	23	6072.200	6	7999.931	35	9675.896	19
3105.340	30	3240.020	25	6072.400	6	7999.932	35	9675.897	19
3105.350	30	3240.060	23	6072.500	6	7999.983	35	9675.898	19
3105.360	30	3240.080	25	6072.600	6	7999.987	35	9761.212	32
3105.370	30	3240.100	23	6072.800	6	820570	35	9762.012	32
3114.200	33	3240.110	23	6074.000	6	822927	35	9762.212	32
3120.200	33	3240.124	23	6074.100	6	823013	35	9765.051	32
3121.000	33	3240.200	23	6074.300	6	823026	35	9768.152	32
3171.100	25	3240.600	23	6074.500	6	9055.310	39	9785.040	42
3172.100	25	3241.100	23	6075.100	6, 7	9055.312	39	9785.042	42
3173.100	25	3241.110	23	6075.300	6, 7	9055.410	39	110010399600	36
3181.100	25	3241.124	23	6075.500	6, 7	9055.412	39	110010399800	36
3182.100	25	3241.600	23	7320.794	42	9640.021	18		
3183.100	25	3243.020	25	7338.160	38	9640.171	18		
3201.200	31	3243.060	24	7338.161	38	9640.181	18		
3201.300	31	3243.080	25	7338.162	38	9640.191	18		
3237.020	25	3243.100	24	7338.163	38	9640.621	19		
3237.060	22	3243.110	24	7338.164	38	9640.628	19		

B	Basic Safe Compact	36	M	Modular Safe	35	– Wall/base mounting bracket, large, CP-C	8
C	Comfort handle	42		Monitor/keyboard unit, 1 U	39	System accessories	
	Connector gland	9	P			– General	42
	– Sealing frame	9		PMC 12 compact	40	– System climate control	33
	– Sealing modules	9		Power Engineering 5.0	12, 13	T	
	Cooling units			PSM/PCU system	41	Therm 6.0 software	33
	– for CS modular enclosures and Toptec	32	R			Thermoelectric cooler	31
	CP-C support arm system	4, 8		Ri4Power	16, 19	TopTherm chillers	26, 27
D				– Angular connectors for Flat-PLS	19	TopTherm fan-and-filter units	20, 25
	Data Centre Container DCC	37		– Busbar support Maxi-PLS	18	– Blanking cover	25
	Digital enclosure internal temperature display and thermostat	33		– Contact piece	18	– Fine filter mats	25
E				– Divider panel module	19	– Hose-proof hood	25
	Enclosure heaters	28, 30		– Isolator chassis	18	– Spare filter mats	25
F				– Longitudinal connector for Maxi-PLS	18	TS 8 server racks	34
	Fire alarm and extinguisher system	38		RiLine60 Plus	14, 15	U	
H				RiZone Management Pack	42	UPS PMC 12 compact	40
	Hygienic Design		S				
	– Terminal boxes HD	10, 11		Semi-cylinder	42		
				Server racks			
				– Based on Rittal TS 8	34		
				Speed control	33		
				Support arm system CP-C	4, 8		
				– Connection adaptor CP-C to CP-L	8		
				– Support section CP-C, open	7		

We reserve the right to further developments and technical modifications of our products. Such modifications, along with errors and printing errata, shall not constitute grounds for compensation. We refer customers to our Terms of Sale and Delivery.

Rittal – The System.

Faster – better – worldwide.

Maximum efficiency, reduced costs, energy savings. Rittal's strategy says think in terms of system solutions and provide a system for all applications – from power distribution and automation, to building installation, through to the IT infrastructure. And offer your customers unprecedented benefits.

- Industrial enclosures
- Power distribution
- Electronic packaging
- System climate control
- IT systems
- Service

Rittal Limited
Braithwell Way · Hellaby Industrial Estate
Hellaby · Rotherham · S Yorks S66 8QY
Tel.: (01709) 704000 · Fax: (01709) 701217
www.rittal.co.uk · eMail: information@rittal.co.uk

07/10 · E901



All supplements to Catalogue 32

FRIEDHELM LOH GROUP

